

B225
USER MANUAL

CONTENTS

| | |
|--|----|
| 1. Introduction | 5 |
| 2. Unpacking..... | 5 |
| 3. Connectors/Cabling | 5 |
| 4. Polarity Checking | 6 |
| 5. Amplification & Power Handling | 6 |
| 6. Crossovers..... | 7 |
| 7. Equalisation | 7 |
| 8. Flying | 7 |
| 9. Positioning | 8 |
| 10. Dimensions | 9 |
| 11. Technical Specifications..... | 10 |
| 12. B225 Service Parts & Accessories | 11 |
| 13. Warranty | 11 |

1. Introduction

Thank you for purchasing Tannoy B225.

The Tannoy B225 is a 15" direct radiating bass loudspeaker system. For installations that require extended bass response from an ultra-compact cabinet, with flying and wall-bracket mount capabilities, the B225 makes the ideal companion to Tannoys' i/T series of sound reinforcement loudspeakers.

The B225 uses a high efficiency 15" driver, combining powerful, natural bass performance with compact dimensions. M10 flying points located around the cabinet mean the B225 can be quickly and easily installed using the EBS10 Eye Bolt Set.

Capable of delivering high sound pressure levels with extremely low distortion, the B225 adds extra low frequencies with traditional Tannoy reliability.

2. Unpacking

Every Tannoy B225 product is carefully inspected before packing. After unpacking your loudspeakers, please inspect for any exterior physical damage, and save the carton and any relevant packaging materials in case the loudspeaker again requires packing and shipping. In the event that damage has been sustained in transit notify your dealer immediately.

3. Connectors/Cabling

The B225 is fitted with two 4-pole Speakon™ connectors. Speakon™ has the following advantages over EP and XLR type connectors: All terminations are solderless, this makes life easier at the time of installation or when field servicing is required. Contacts will accept 6 sq. mm wire with an outside diameter of up to 15 mm and a current rating of 30 Amps.

The pins of the two Speakon™ sockets, marked input/output on the rear of the input panel, are paralleled within the enclosure.

Tannoy have adopted the following wiring standard for B225:-

| SPEAKON™ CONNECTOR | SIGNAL |
|-------------------------------|-----------------|
| Pin 1+ | Positive |
| Pin 1- | Negative |

Should you encounter any problems obtaining Speakon™ connectors, please contact Neutrik or its distributors on the following numbers:-

UK: NEUTRIK MARKETING: 01983 811 441

USA: NEUTRIK USA INC.: +1 732 901 9488

For a worldwide list of distributors, please contact Neutrik directly on:-

NEUTRIK AG: +423 237 2424

or visit their website at: <http://www.neutrik.com/>

Cable choice consists mainly of selecting the correct cross sectional area in relation to the cable length and the load impedance. A small cross sectional area would increase the cables series resistance, inducing power loss and response variations (damping factor).

Connectors should be wired with a minimum of 2.5 sq. mm (12 gauge) cable. This will be perfectly satisfactory under normal conditions. In the case of very long cable runs the wire size should exceed this, refer to the following table for guidance:-

| CABLE RUN (m) | C.S.A. OF EACH CONDUCTOR (mm) | CABLE RESISTANCE W | % POWER LOSS INTO 8W LOAD | % POWER LOSS INTO 4W LOAD |
|---------------|-------------------------------|--------------------|---------------------------|---------------------------|
| 10 | 2.5 | 0.14 | 1.7 | 3.5 |
| | 4.0 | 0.09 | 1.1 | 2.2 |
| | 6.0 | 0.06 | 0.73 | 1.5 |
| 25 | 2.5 | 0.35 | 4.3 | 8.6 |
| | 4.0 | 0.22 | 2.7 | 5.4 |
| | 6.0 | 0.14 | 1.8 | 3.6 |
| 50 | 2.5 | 0.69 | 8.6 | 17.0 |
| | 4.0 | 0.43 | 5.4 | 11.0 |
| | 6.0 | 0.29 | 3.6 | 7.2 |
| 100 | 2.5 | 1.38 | 17.0 | 35.0 |
| | 4.0 | 0.86 | 11.0 | 22.0 |
| | 6.0 | 0.58 | 7.2 | 14.0 |

4. Polarity Checking

It is most important to check the polarity of the wiring. A simple method of doing this without a pulse based polarity checker for LF units is as follows: Connect two wires to the +^{ve} and -^{ve} terminals of a PP3 battery. Apply the wire which is connected to the +^{ve} terminal of the battery to the speaker cable leg which you believe to be connected to Pin 1+ of the speaker connector and likewise the -^{ve} leg of the battery to Pin 1-.

If you have wired it correctly the LF drive unit will move forward, indicating the wiring is correct. All that remains now is to connect the +^{ve} speaker lead to the +^{ve} terminal on the amplifier and the -^{ve} lead to the -^{ve} terminal on the amplifier. If however the LF driver moves backwards, the input connections need to be inverted.

If problems are encountered, inspect the cable wiring in the first instance. It should also be noted that different amplifier manufacturers utilise different pin configurations and polarity conventions. If you are using amplifiers from more than one manufacturer, check the polarity at the amplifiers as well as the loudspeakers.

5. Amplification & Power Handling

As with all professional loudspeaker systems, the power handling is a function of voice coil thermal capacity. Care should be taken to avoid running the amplifier into clip (clipping is the end result of overdriving any amplifier). Damage to the loudspeaker will be sustained if the amplifier is driven into clip for any extended period of time. Headroom of at least 3dB should be allowed. When evaluating an amplifier, it is important to take into account its behaviour under low impedance load conditions. A loudspeaker system is highly reactive and with transient signals it can require more current than the nominal impedance would indicate.

Generally a higher power amplifier running free of distortion will do less damage to the loudspeaker than a lower power amplifier continually clipping. It is also worth remembering that a high powered amplifier running at less than 90% of output power generally sounds a lot better than a lower power amplifier running at 100%. An amplifier with insufficient drive capability will not allow the full performance of the loudspeaker to be realised.

It is important when using different manufacturers amplifiers in a single installation that they have very closely matched gains, the variation should be less than +/- 0.5dB. This precaution is important to the overall system balance when only a single compressor/limiter or active crossover is being used with multiple cabinets; it is therefore recommended that the same amplifiers be used throughout.

6. Crossovers

For optimal performance the B225 has been designed to operate with Tannoy Install or Transportable series, e.g. i12/T12, i15 and T300, where overall system control is achieved by utilising the TDX2 system controller. The TDX2 has been factory preset to provide the recommended cross-over points, delays and overall system balance. Please refer to the TDX2 manual for operation. Alternatively, Tannoy TX1, TX2 and TX3 system controllers can be used.

If you intend using an alternative loudspeaker management system (e.g. BSS™, Klark Teknik™, XTA™ etc) please contact your distributor or visit our website, www.tannoy.com for the correct parameter settings or refer to the recommended crossover points in the technical specifications section of this manual.

7. Equalisation

The B225 loudspeaker is designed to need no equalisation or correction to overcome system limitations. As a result, it will only need equalisation to compensate for difficult acoustic environments.

Over equalisation can reduce system headroom, and introduce phase distortion resulting in greater problems than cures. If equalisation is required then it should be applied gently and smoothly. Violent equalisation will be detrimental to the overall sound quality.

8. Flying

The B225 utilises convenient M10 flying points where the unit can be flown, by utilising the EBS10 Eye Bolt Set allowing for ease of installation and flexibility with the highest levels of safety. As with any flying system, safety can only be guaranteed when all precautions have been implemented correctly.

NOTE: The installation of this product must be carried out in conformity with local building codes and standards. If necessary, consult your local safety standards officer before installing any product. Alternatively, check any laws or bylaws. Tannoy will not be held responsible for any damage caused by the improper installation of any flying gear or loudspeaker.

9. Positioning

When a bass loudspeaker is used in an environment with boundary surfaces, its placement affects its frequency response. When such effects are properly understood, they can be used to great effect in producing the desired sound quality without the aid of additional amplification.

Consider *Figure 9a* in the diagram below, here we see a loudspeaker in free field or anechoic conditions. We measure its sound pressure level at a distance D , and refer to this as our reference level, or 0 dB SPL.

If we now place a large reflective surface (i.e., a wall, ceiling or floor) next to the loudspeaker, see *Figure 9b*, the sound that is radiated towards the boundary is reflected. As a result, the sound pressure level can increase by as much as 3 dB (effectively doubling the available amplifier power). The loudspeaker is radiating its power into half as much space, this is known as *half space loading*. For each additional boundary the SPL can increase by 3dB. Corner placement or eighth space (*Figure 9d*) loading can increase a bass speaker's efficiency by up to 9dB.

This effect is not the same at all frequencies. Loudspeakers are only essentially omnidirectional at low frequencies (where the wavelength is large in comparison to the loudspeaker). At high frequencies sound radiates in a more directional manner. We can position full range loudspeakers next to a boundary in order to boost the lower frequencies while the highs remain unchanged.

Coupling, or placing bass cabinets together will also increase bass output.

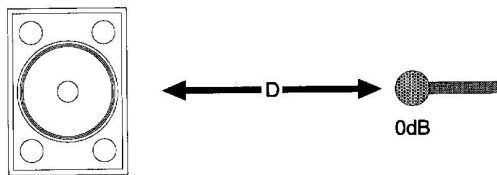

Figure 9a. Free Space

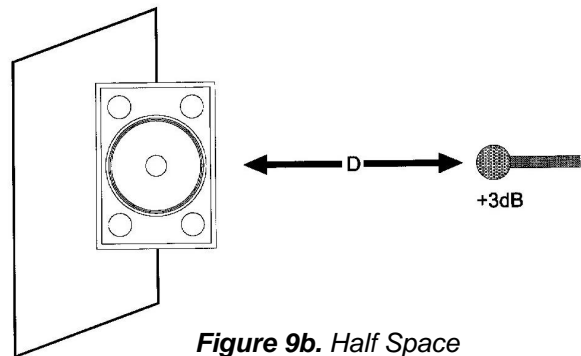

Figure 9b. Half Space

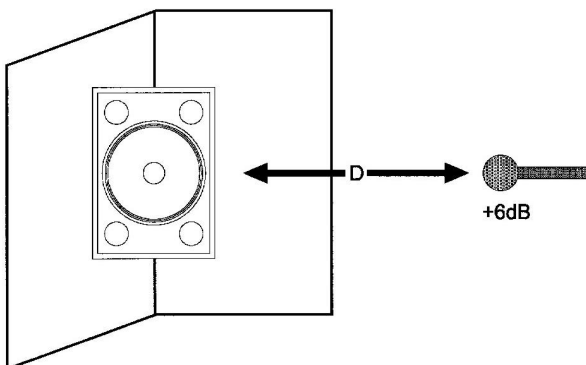

Figure 9c. Quarter Space

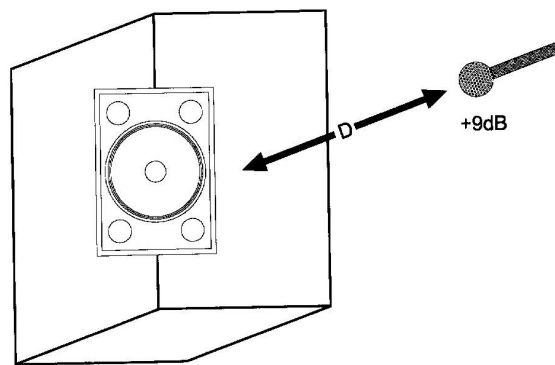
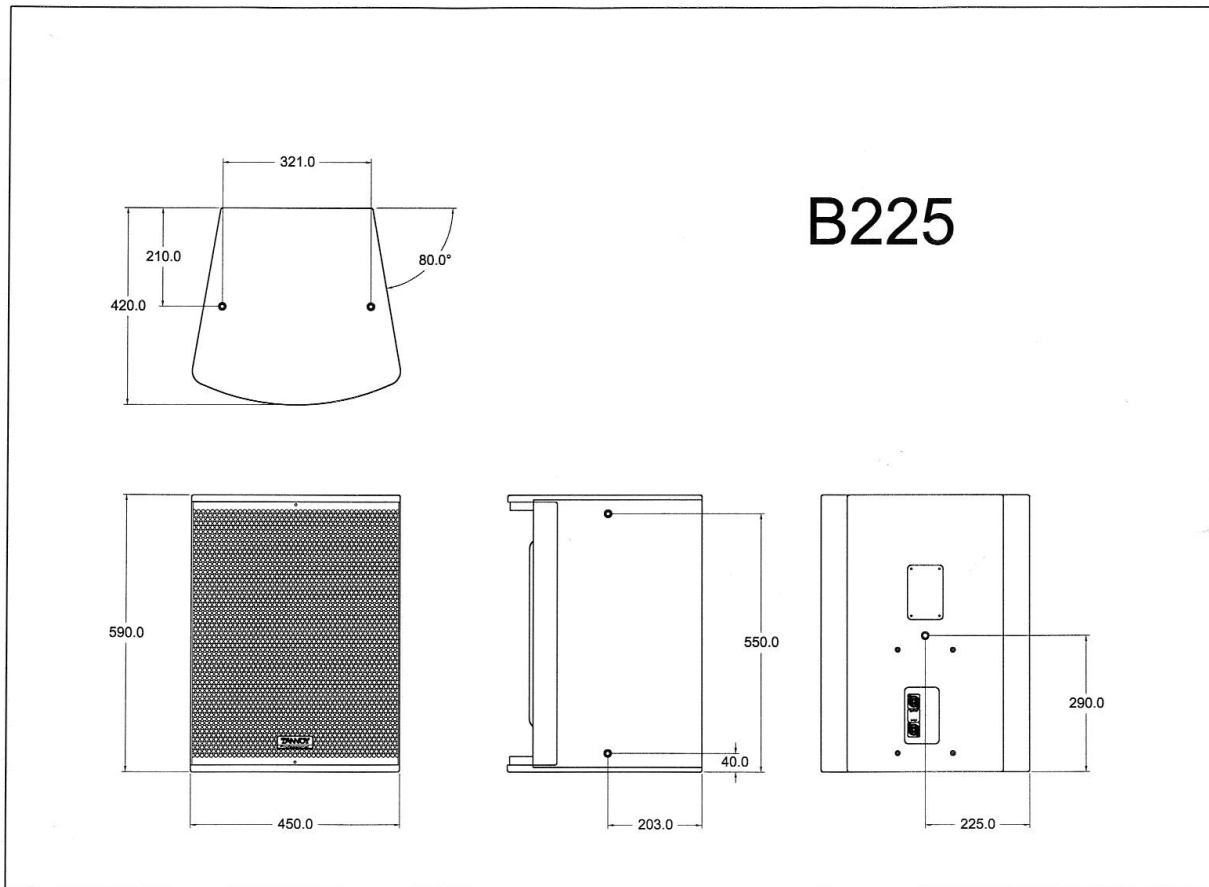

Figure 9d. Eighth Space

10. Dimensions



11. Technical Specifications

| | | | |
|---|---|--------------------------|--------------------------|
| Frequency response (1) +/- 3dB | 50Hz - 2kHz | | |
| Recommended Amplifier Power | 400 - 800 Watt / 8Ω | | |
| Power Handling | Average(2) 400 Watt | Programme 800 Watt | Peak (10ms) 1600 Watt |
| Sensitivity (1) 2.83 volt @ 1m | 95dB | 98dB (half space) | |
| Maximum SPL (3) @ 1m | Average 121dB | Peak 127dB | |
| Impedance | Nominal Minimum | 8Ω 7Ω | |
| Distortion | | | |
| 0.1 Full Power | 2 nd Harmonic | 3 rd Harmonic | |
| 100 Hz | 1.37% | 0.57% | |
| 250 Hz | 0.63% | 0.451% | |
| 0.01 Full Power | 2 nd Harmonic | 3 rd Harmonic | |
| 100 Hz | 0.42% | 0.149% | |
| 250 Hz | 0.35% | 0.312% | |
| Driver Complement | 1 x 15" High efficiency bass unit, Type 3814 | | |
| Crossover Point | Active: Recommended points 100-300 Hz, 24dB/octave, Linkwitz – Riley (depending on application) | | |
| Enclosure | 65 litre, vented MDF | | |
| Finish | Textured black/grey paint | | |
| Protective Grille | Black Perforated Steel | | |
| Connectors | 2 x Speakon™ NL4MP – in/out | | |
| Fittings | 8 x M10 flying inserts | | |
| Dimensions | 590mm (H) x 450mm (W) x 420mm (D) 23.2" (H) x 17.7" (W) x 16.5" (D) | | |
| Weight | 24.0 kg (52.8 lbs) | | |

NOTES:

- (1) Average over stated bandwidth. Measured at 1m on axis, in an anechoic chamber.
(2) Long term power handling capacity as defined in EIA standard RS - 426A.
(3) Unweighted pink noise input, measured at 1m

Tannoy operates a policy of continuous research and development. The introduction of new materials or manufacturing methods will always equal or exceed the published specifications which Tannoy reserve the right to alter without prior notice. Please verify the latest specifications when dealing with critical applications

12. B225 Service Parts & Accessories

| Part Number | Description |
|-------------|--|
| 7900 0597 | Driver Kit Type 3814 |
| 7900 0601 | Recone Kit Type 3814 |
| 8001 2190 | EBS10 Eye Bolt Set M10 |
| 8000 0727 | TDX2 Digital loudspeaker management system 60-250V - UK |
| 8000 0728 | TDX2 Digital loudspeaker management system 60-250V - EUR |
| 8000 0729 | TDX2 Digital loudspeaker management system 60-250V - USA |

13. Warranty

No maintenance of the B225 loudspeaker is necessary.

All Tannoy professional loudspeaker products are covered by a 5-year warranty from the date of manufacture subject to the absence of misuse, overload or accidental damage. Claims will not be considered if the serial number has been altered or removed. Work under warranty should only be carried out by a Tannoy Professional dealer or service agent. This warranty in no way affects your statutory rights. For further information please contact your dealer or distributor in your country. If you cannot locate your distributor please contact Customer Services, Tannoy Ltd at the address given below.

Customer Services
Tannoy Ltd.
Coatbridge
ML5 4TF
Scotland
Telephone: 01236 420199 (National)
+44 1236 420199 (International)
Fax: 01236 428230 (National)
+44 1236 428230 (International)
E-Mail: service@tannoy.com
Website: www.tannoy.com

DO NOT SHIP ANY PRODUCT TO TANNOY WITHOUT PREVIOUS AUTHORISATION

Our policy commits us to incorporating improvements to our products through continuous research and development. Please confirm current specifications for critical applications with your supplier.

EASE Data for Tannoy Professional products available on request.

Tannoy Limited, Professional Division, Coatbridge, Strathclyde, ML5 4TF, Scotland.
Tel: +44 (0) 1236 420199 Fax +44 (0) 1236 428230
e-mail: prosales@tannoy.com Website: www.tannoy.com

Tannoy / TGI North America Inc., 335 Gage Avenue, Suite 1, Kitchener, Ontario, Canada N2M 5E1.
Tel: (519) 745-1158 Fax: (519) 745-2364
e-mail: inquiries@tgina.com Website: www.tannoy.com

Tannoy Nederland b.v., Anthonetta Kuijlstraat 19, 3066 GS Rotterdam.
Tel: (010) 286 0554 Fax: (010) 286 0431
e-mail: info@tannoy.nl Website: www.tannoy.nl

Tannoy is a member of the  Group of Companies

ML 27th March 2001